

## IPS OD fittings for IPS OD (DR) PE Pipe (suits PE to ASTM D3035 or ASTM D2447)

3G™ compression fittings are not just the new generation of pipe fittings for IPS OD PE Pipes – they are the next generation. The culmination of years of exhaustive research and development, utilization of cutting-edge manufacturing technology and stringent testing, this new range of premium products represents Philmac's most exciting generation of plastic compression fittings.

Featuring Philmac's unique Slide & Tighten™ technology, 3G™ compression fittings for IPS OD PE Pipes makes installation easy – no insert is required and no force is needed to push the pipe in. And a visual stop reduces the risk of overtightening.

Importantly, the fittings have been manufactured from high performance, advanced thermoplastic materials so they are resistant to corrosion and have the strength and durability to provide a 50+ year service life.

The 3G™ range of plastic compression fittings are the product of Philmac's unrelenting commitment to continuous improvement and a culture based on innovation and ingenuity.

### STANDARDS

The Philmac 3G™ range of compression fittings are CSA and NSF approved for potable water use.



## 3G™ BENEFITS

### Fast and easy installation

- **Slide & Tighten™ technology:** 3G™ compression fittings incorporate all the benefits of Philmac's unique Slide & Tighten™ technology. No pipe preparation is needed and no force is required to push the pipe past the seal, so installation couldn't be faster or easier. Simply insert the pipe into the fitting until the first point of resistance is felt, and then tighten the nut. Assembly is so easy you can even do it under live conditions. Also, there is no need to disassemble the fitting before use because 3G™ compression fittings are supplied pre-assembled and ready to use.
- **Compact design:** The size of the new Philmac 3G™ compression fitting has been kept to a minimum, making the fitting ideal to use in confined areas. In addition to making connections with minimal turns of the nut, the design and size of the fittings means that in installations taking place between two fixed points, the manipulation of the pipe into the fitting becomes easy.
- **Easy disassembly:** The fitting has been designed so the split collet is released as soon as the nut is backed off, making disassembly easy.

### Complete security

- **Visual stop:** The flange on the body of the 3G™ compression fitting provides a visual stop to indicate when the nut is fully tightened. This removes any uncertainty from the installation process and eliminates the risk of over-tightening.
- **No loose components:** If the nut is removed there is no danger of losing components, as the collet and seal ring are retained in the body of the fitting. Losing components in the trench becomes a thing of the past.
- **Dynamic sealing method:** The mechanical advantage of the nut thread compresses the seal into position, eliminating resistance when inserting the pipe into the fitting so there is no risk of seal distortion or displacement.
- **Designed to minimize pipe twist:** The fitting has been designed to minimize pipe twist as the nut is tightened. Maximum pipe twist is approximately a quarter turn compared to one and a half turns with many other fittings. Pipe twist can impact on not only the connection you have just made but also on the connection at the other end of the line.
- **Approvals:** Philmac 3G™ compression fittings are CSA and NSF approved for potable water use.

### High performance

- **Made from advanced thermoplastic materials:** 3G™ compression fittings are manufactured from lightweight high performance thermoplastic materials which, unlike metal fittings, resist corrosion, therefore significantly minimizing maintenance, repairs and long-term costs. The materials are non-toxic and taint-free and also offer outstanding impact, UV and chemical resistance.
- **Rated to 230psi:** 3G™ compression fittings are pressure rated to 230psi to meet the needs of high pressure systems.
- **50 year+ design life:** Built to withstand the toughest conditions to ensure longevity and durability, 3G™ compression fittings have a 50 year+ design life.

### Complete coverage

- **Wide range:** The new 3G™ compression fittings range is comprehensive: straight and reducing couplers, tees, elbows, male and female adapters and caps ranging from 3/4" to 2".
- **Copper connection kits:** Philmac's all new carborundum gripper design has been introduced into the 3G™ copper connection kit. With no steel components in the gripping mechanism, there is absolutely no risk of electrolysis.



## IPS OD INSTALLATION INSTRUCTIONS



### 1. Cut Pipe Square

Cut the pipe square. There is no need to prepare the pipe end.

Chamfering or lubrication is not required.



### 2. Ready to Use Position

The fitting is pre-assembled and ready to use, however always ensure the nut is fully relaxed and 2 threads are showing before inserting the pipe.



### 3. Pipe Insertion

Insert the pipe until the first point of resistance is felt.



### 4. Nut Tightening

The nut should be tightened by hand and then firmly with a wrench. Tighten the nut until it just touches the flange on the body of the fitting.



### 5. Check for Correct Installation

Ensure the nut is tightened until flush with the flange on the body of the fitting. Fitting is now fully installed.



### 6. Disassembly

To disassemble the fitting simply loosen the nut using a wrench until 2 threads are showing. Pipe will be released and can simply be pulled out of the fitting.

**Note:** Philmac recommends the use of PTFE tape on NPT threads to ensure a positive seal.

## MATERIALS & COMPONENTS

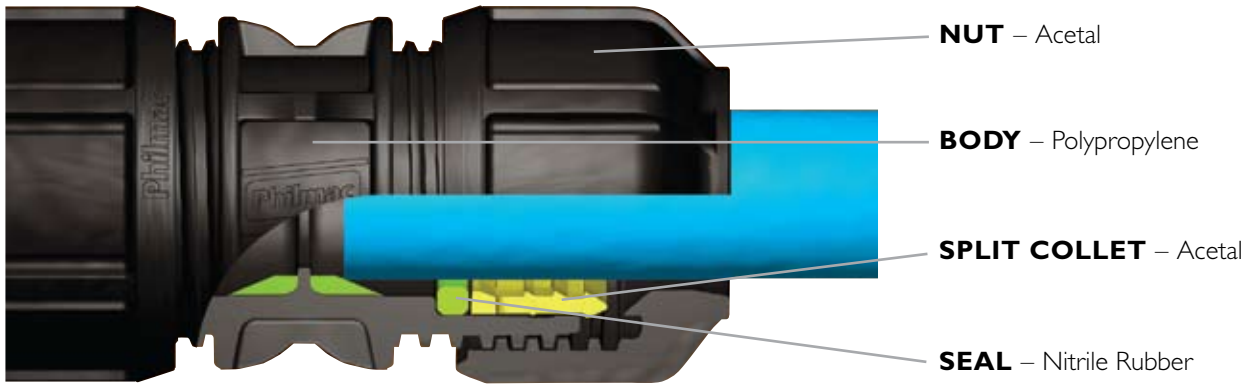

## PRINCIPALS OF OPERATION

### FULLY OPEN

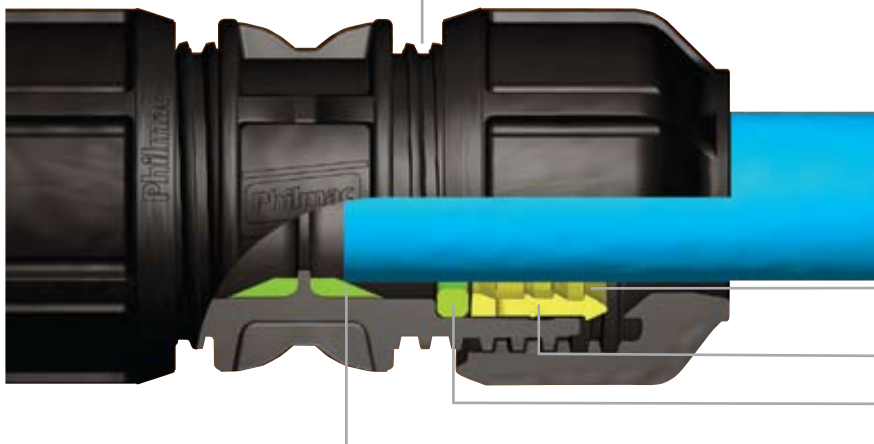

Fitting is pre-assembled ready to use in the open position with 2 threads showing.

Clearance between the pipe and fitting allows for easy insertion of the pipe.

Split collet, which is in relaxed position.

Seal, which is in relaxed position.

The pipe sits against the tapered wedges which minimizes pipe rotation.

### FULLY CLOSED



Split collet bites into the pipe providing end load resistance.

Positive internal stop when nut meets flange of the body.

Nut and then split collet has fully compressed the seal. Seal ring compression is achieved by exploiting the mechanical advantage of the nut thread.